

# **Embedded Local Monitor Board**

## **1. Introduction**

The ATLAS DCS consists of two components, the Supervisory Control And Data Acquisition (SCADA) system and the Front-End I/O (FEIO) system. The aim is to have an as homogeneous system as possible for all subdetectors. On the SCADA side this is guaranteed by using the same commercial software system throughout. The connection of the SCADA to the FEIO will be achieved by a limited number of standards such as CAN fieldbus, OPC software etc. The FEIO is the responsibility of the subdetector group, but a versatile general purpose system, the Local Monitor Box (LMB) has been designed and built and is now widely accepted by the subdetector groups.

After successful tests of the LMB and feedback from the subdetector groups a new version, the Embedded Local Monitor Board (ELMB) has been designed. It has many more functions as compared to the LMB and its packaging follows the subdetectors' needs. The main differences are, that the ELMB comes in the form factor of a credit-card sized piggy board and that it has many digital I/O lines which can be fully programmed by the (advanced) user. For standard application a library will be provided in order to avoid for the normal user the need of programming knowledge of the micro-controller. As an option the ELMB comprises a multiplexed 64-channel ADC with 16+7-bit resolution which can be used from the SCADA system without dedicated programming. The board can either be directly plugged onto the subdetector front-end electronics, or onto a general-purpose motherboard, which adapts the I/O signals.

The environmental requirements are essentially unchanged. It should be usable in USA15 outside of the calorimeter in the area of the MDTs and further out. This implies tolerance (with safety factors) to radiation up to about 5 Gy and  $3 \cdot 10^{10}$  neutrons/cm<sup>2</sup> for a period of 10 years and to a magnetic field up to 1.5 T.

## **2. Overview**

The ELMB is a general-purpose plug-in board. A block diagram of the ELMB is shown in Fig.1. It is based on an AVR microcontroller ATmega103. There is a second microcontroller AT90S2313 for in system programming and monitoring functions. The CAN controller is based on a SAE81C91. A galvanic isolation to the CAN bus is made with fast optocouplers between the CAN bus transceiver PCA82C251 and protocol chip. There is a DIP switch for the baud rate and the CAN identifier. Three low-drop power regulators are used as filters and with current limitation for the different voltages needed. All of these components are mounted on a PCB of the size 50 x 66 mm. On the backside of this PCB are two high-density connectors of SMD type and optionally a high-performance 16+7 bit delta-sigma ADC with 64 differential inputs. There are also analog power regulators for the supply of the ADC.

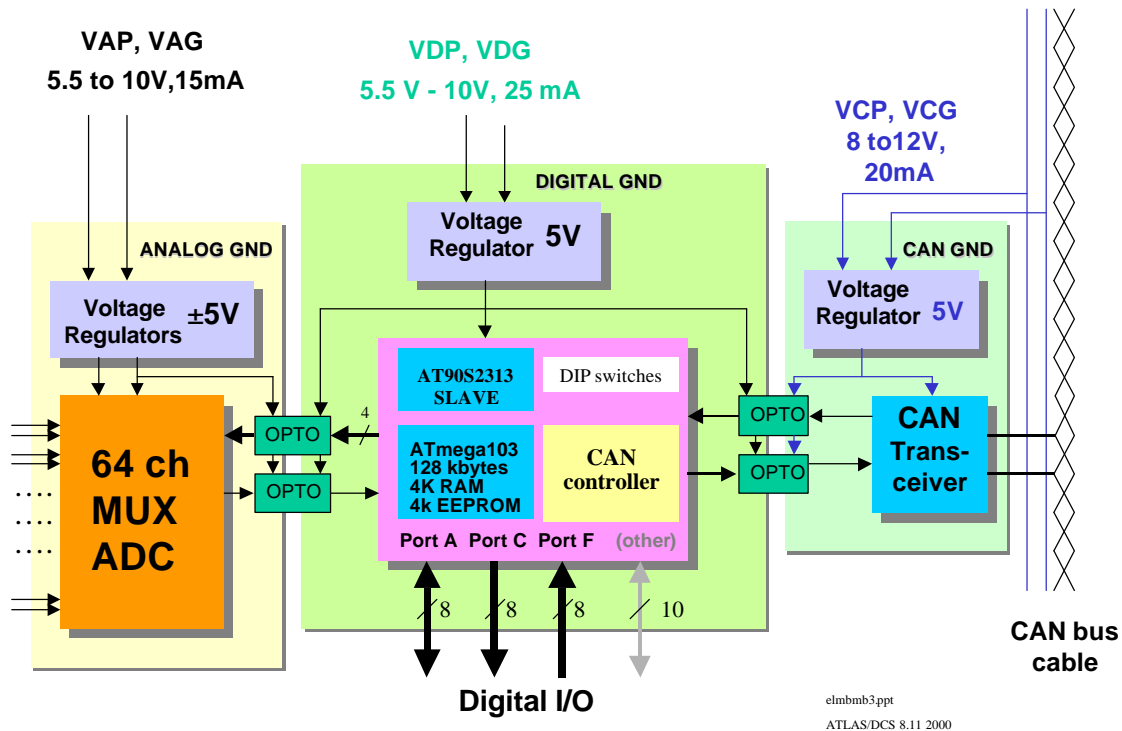

Figure 1 Block diagram of Embedded Local Monitor Board

### 3.0 Features of the ELMB

The ATmega103 runs at a 4 MHz clock speed. It has RISC architecture with 121 mostly single clock instructions. The main features of the LMB board are:

#### AVR RISC architecture ATMEL Atmega103

- 128 kbytes of on-chip flash memory,
- 4 kbytes of SRAM
- 4 kbytes of EEPROM.
- In-System Programming via CAN bus

#### Peripheral Features

- Full CAN controller interface with PCA82C250
- 6 bit CAN identifier and 4 baud rates supported.
- 3-wire SPI interface
- Real Time Counter with a separate 32 kHz crystal
- Timers
- 8-channel 10-bit ADC

#### I/O lines available

- 6 external interrupt inputs
- Port A 8 digital bi-directional I/O lines (can alternatively be used for external SRAM).
- Port C 8 digital output lines (can alternatively be used for external SRAM).
- Port D 5 digital bi-directional I/O lines
- Port E 5 digital bi-directional I/O lines
- Port F 8 digital input lines or 8 analog inputs for the ADC
- Strobe and enable lines for external SRAM

The digital outputs are capable of driving several TTL loads (sink 10mA) and the inputs have Schmitt trigger inputs.

**Power regulators**

- Separate regulator for the CAN bus transceiver and optocouplers
- Regulator for the microcontrollers
- Voltage converter 3.3V to 5.4V

**Optional Delta-sigma ADC CRYSTAL CS5523 with 64 channel multiplexer**

- 6 bipolar or unipolar input ranges from 25mV to 4.5V
- 100 pA input current on 25mV,55mV and 100mV
- 10nA on 1V, 2.5V and 5V ranges
- 8 conversion rates from 2 Hz to 100Hz
- 64 channel multiplexer
- +5V and -5V on board power regulators

**Mechanical dimensions**

- The size of the printed circuit board is 50x66mm.
- The board is equipped with two connectors with either 100 pins or 40 pins (the latter if no ADC options).

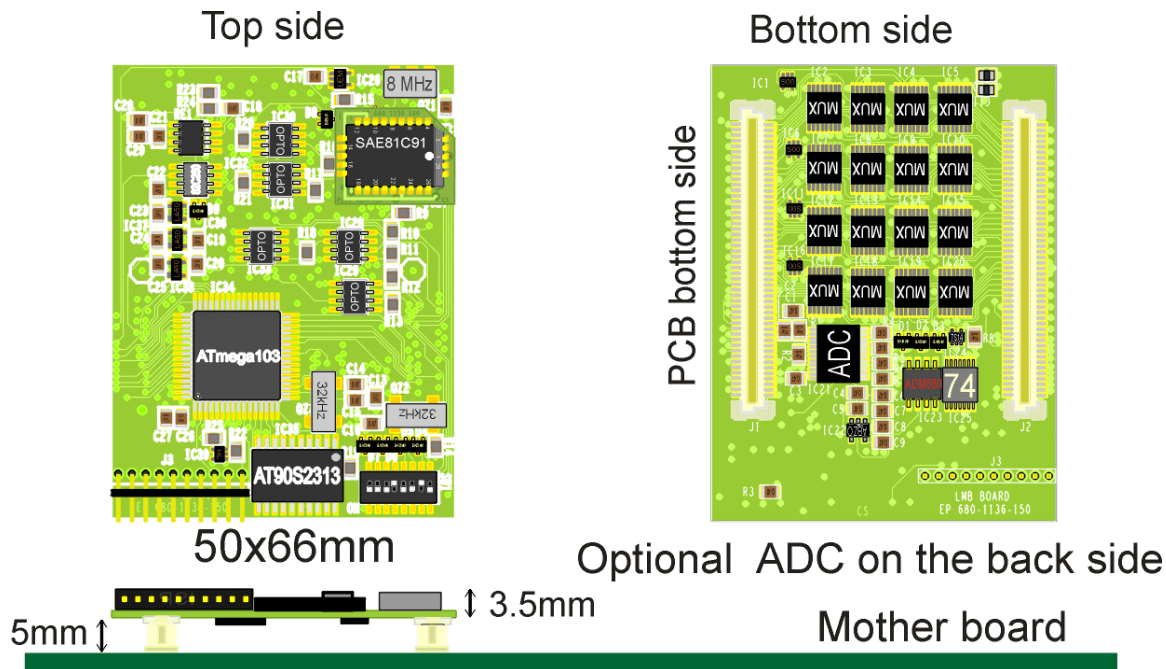

Figure 2 Implementation of the ELMB

#### 4. Motherboard support and testbox for the ELMB

In order to test the ELMB a motherboard is available. It contains on the backside two 100-pin SMD connectors for the ELMB and sockets for adapters for the 64 channel ADC. The motherboard may be mounted in DIN rail housing of the size 80 x 180 mm. On the front side there are connectors for the ADC inputs, digital ports, a SPI interface, CAN interface and power connectors, see Fig.3.

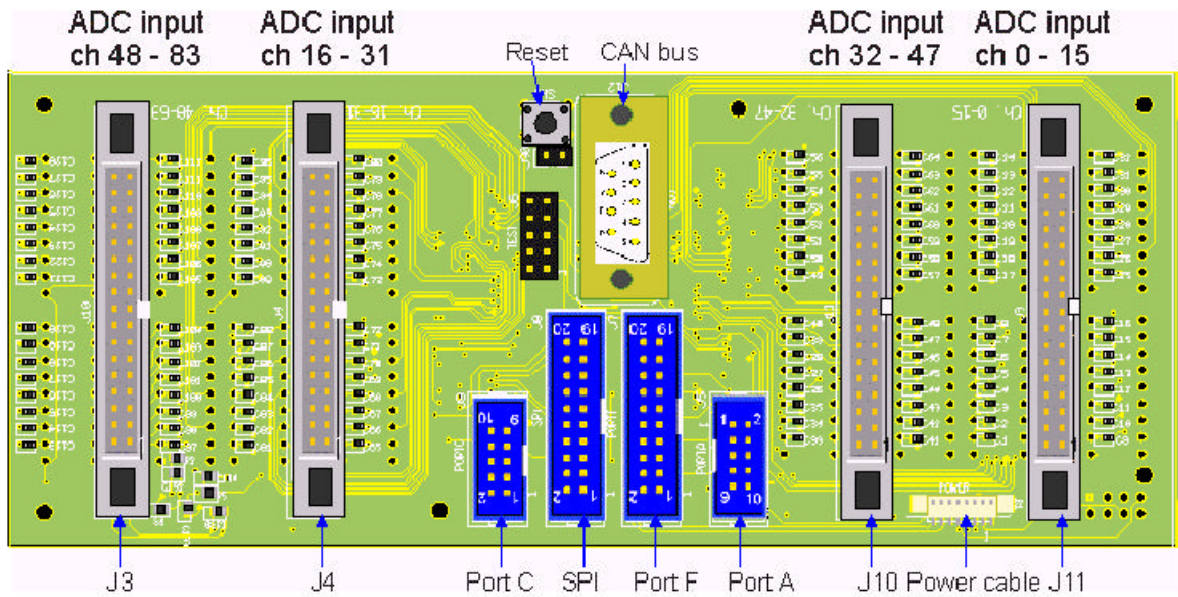

Figure 3 Motherboard for testing the ELMB

#### I/O ports available

- Four differential 16 channel ADC inputs (connectors 34 pin type 3M 3431) each input can be personalized with 4 plug-in DIL socket.
- One 8 bit bi-directional digital I/O (PORT A) capable of sinking 20 mA on a 10 pins 2.54 mm header connector.
- One 8 bit digital output port (PORT C) capable of sinking 20 mA on a 10 pins 2.54 mm header connector.
- One 8 bit input digital input port (PORT F). This port also serves as analog input for the ATmega103 ADC. The connector is 20 pins 2.54 mm header connector.
- One Serial Peripheral Interface (SPI) connector with SCLK, DIN, DUT and 10 CS lines. There are also +5V and -5V power supplies available. This port is compatible with the LMB ADC/Pt100 modules from the previous series production.
- SPI-interface compatible with the LMB CAN module.
- Power connections with special cable supplied.
- Optional test connector for the internal power supply of the ELMB for use in a test box.

## 5. Signal adapters for the ELMB motherboard

On the backside of the motherboard there are spaces for 16 sockets for dual-in-line signal adapters, each servicing 4 input channels. There are presently adapters for 4-wire Pt100 sensors, 2-wire resistive sensors and differential voltage attenuators. The ADC voltage reference (+2.5V) and the analog ground are available on each adapter. Different types of adapters may be mixed, however it is required that the same ADC range should be used for all of them. In addition common resistor networks may be used in the sockets for the direct connections to the onboard multiplexer and ADC.

- **High performance Pt100 adapter.**

Four-wire connection to the sensor eliminates the voltage drop in the wires, see Fig.4. Two channels of the ADC are used. The sensor resistance is given by the ratio of the ADC readings for ch1 and ch0 times value of the RS resistor. Therefore the performance is essentially given by the quality of the resistor RS. A high stability type is recommended. The resistor RC determines the current through the sensor. It should be scaled such that the full-scale range of the ADC used is below 100mV. In that case the input current of the ADC can be neglected (~100pA). Calibration has to be done by exchanging the sensor with a known stable high-precision resistor. The motherboard has place for four adapters of the type shown in Fig.5 per 16 channel inputs

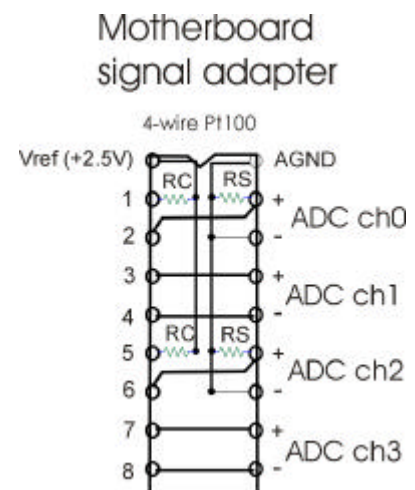
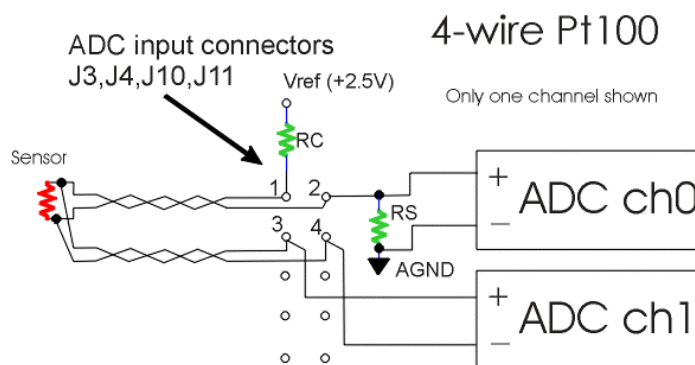

Fig.4 Principle of the 4-wire resistance measurement. Fig. 5 Plug-in adapter for 2 channels

- **Resistance Temperature Detector (RTD) sensors**

RTD sensors (for example NTC 10k or Pt10000) but also other sensors like strain gauges and position sensors where the resistance changes as function of the parameter can be measured with this adapter. The principle of 2-wire measurements of resistive sensors is shown in Fig. 5. The resistance of the connection wire will influence the accuracy of the measurements but this effect can be reduced by calibration. The input current of the ADC has also to be taken into account. The circuit should be calibrated by replacing the sensor with a known precision

resistor. About 10mA per input connector (16 channels) is available from the Vref in Fig.5. The Vref is generated with the help of a stable precision operational amplifier from the same reference voltage as is used by the ADC. The adapter is shown in Fig.7. The value of the resistors in Fig7 for 10 kohms@25°C NTC resistors is chosen to be 1 Mohm. This permits measurements of temperatures in the range from -5°C to >100°C at a constant ADC input voltage range of 100 mV.

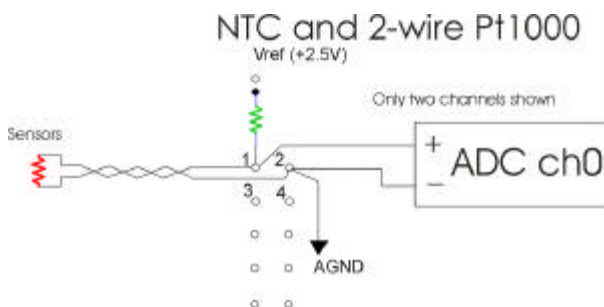

Fig. 6 Principle of the 2-wire measurements

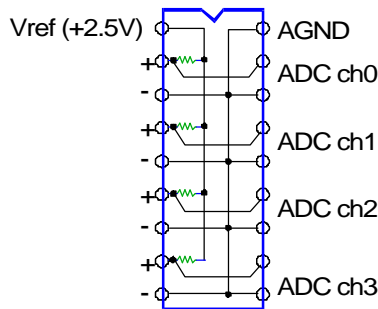

Fig. 7 Plug-in adapter for 4 channels

- **Differential attenuator**

The Crystal Semiconductor ADC CS5523 used in the ELMB with the input multiplexer can measure voltages up to the range from -4.5V to 4.5V. The common mode range is -0.15 V to 0.95V on the three lowest voltage ranges and -2V to 5V in the other ranges. With the help of a differential attenuator the input ranges of the ADC can be extended see Fig.8. The ratios of R1 to R2 and R3 to R4 should be matched to the wanted range. The value of the resistors should be chosen so that ground loop currents can be neglected (>100 kohms). The adapter is shown in Fig.9.

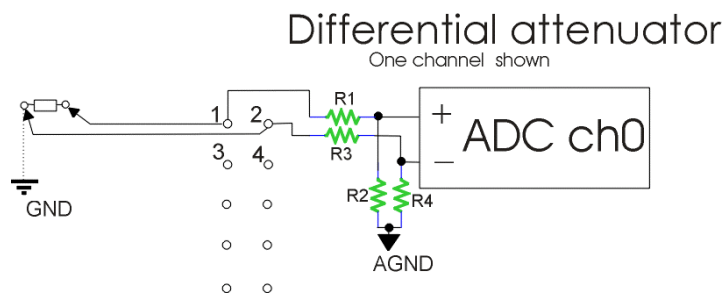

Fig. 8 Principle of differential attenuator

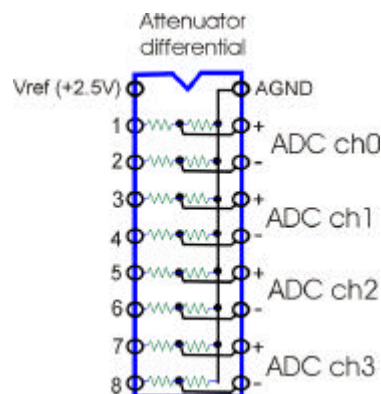

Fig. 9 Plug-in with differential attenuators

- **Resistor network**

A standard 16 pin dual-in-line resistor network can be used, see Figure 10. This connects the external connector directly to the analog multiplexers of the ADC. It should be noted that the input voltage range is limited ( $< \pm 4V$ ) and not protected against over voltages! Also the common mode range is limited depending on the ADC range used.

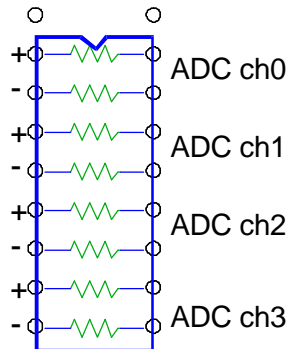

Figure 10 Resistor network

In order so that the bias/leakage currents of the input multiplexer and ADC should not influence the measurements resistors value of less than 1kohms should be used.

#### 4.0 Documentation

All documentation of the ELMB and motherboard (MB) including the schematics and pin descriptions of all the connectors are available at

<http://atlasinfo.cern.ch/ATLAS/GROUPS/DAQTRIG/DCS/LMB/SB/index.html>